

Saramonic

Full-Duplex Wireless Intercom Headset System
全双工无线对讲耳机系统

WiTalk System



Statement

Please read this manual carefully before using the products and strictly operate & store it in accordance with the instructions. Please save the manual for your future reference. If you need further assistance than the user manual, please consult your retailer for help or email us :
info@saramonic.com.

Introduction

WiTalk series is a full-duplex wireless intercom headset system that offers two-way communication at a range of up to 400m. WiTalk system is ideal for applications where teams need full use of their hands, such as filmmaking, sports events, production crew communication, etc. It mainly includes the following product:

WiTalk HUB, a mini base station with two operating channels, can work with eight Remote headsets simultaneously. Its 3.5mm headphone & microphone combo jack can be connected to the WiTalk LBH (monaural intercom headset), creating a nine-person talk net.

Both WiTalk DMH (dual-ear master headset) and WiTalk SMH (single-ear master headset) can be used with four Remote headsets, allowing up to 5 people to communicate simultaneously.

Both WiTalk DRH (dual-ear remote headset) and WiTalk SRH (single-ear remote headset) can be paired with any kind of master headset or base station.

WiTalk CB, a battery charger, can charge up to 10 batteries at the same time.

Product Structure

WiTalk DMH: Dual-Ear Master Headset

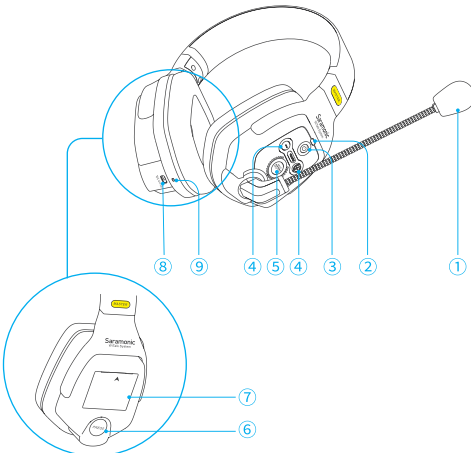

① Microphone

② Status Indicator

③ Power Button

Press and hold to power on or off.

④ Volume Control (+/- button)

Press "+" or "-" button to increase or decrease the volume.

⑤ Mute Button

Mode	Status Indicator
Mute	Blinking red
Not mute	Static blue

⑥ Release Button

⑦ Battery Compartment

⑧ USB-C Charging Port

⑨ Charging Indicator

WiTalk DRH: Dual-Ear Remote Headset

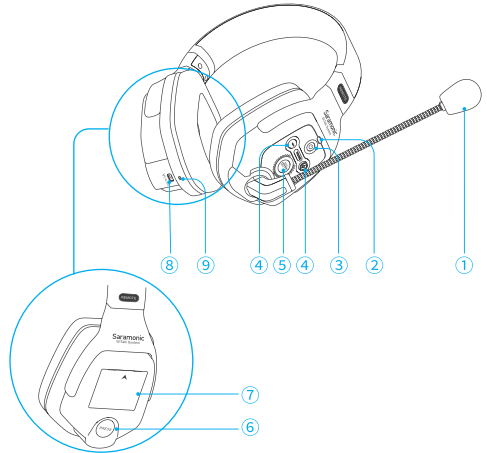

① Microphone

② Status Indicator

③ Power Button

Press and hold to power on or off.

④ Volume Control (+/- button)

Press "+" or "-" button to increase or decrease the volume.

⑤ Mute Button

Mode	Status Indicator
Mute	Blinking red
Not mute	Static blue

⑥ Release Button

⑦ Battery Compartment

⑧ USB-C Charging Port

⑨ Charging Indicator

WiTalk SMH: Single-Ear Master Headset

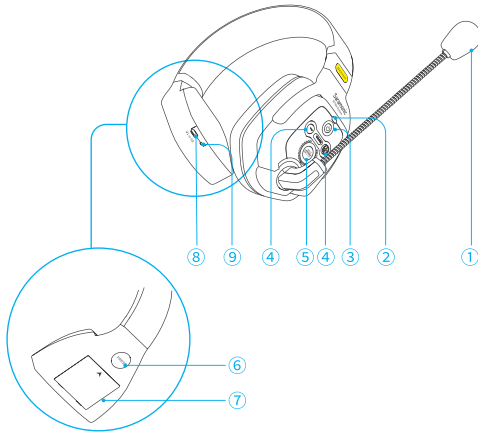

① Microphone

② Status Indicator

③ Power Button

Press and hold to power on or off.

④ Volume Control (+/- button)

Press "+" or "-" button to increase or decrease the volume.

⑤ Mute Button

Mode	Status Indicator
Mute	Blinking red
Not mute	Static blue

⑥ Release Button

⑦ Battery Compartment

⑧ USB-C Charging Port

⑨ Charging Indicator

① Microphone

② Status Indicator

③ Power Button

Press and hold to power on or off.

④ Volume Control (+/- button)

Press "+" or "-" button to increase or decrease the volume.

⑤ Mute Button

Mode	Status Indicator
Mute	Blinking red
Not mute	Static blue

⑥ Release Button

⑦ Battery Compartment

⑧ USB-C Charging Port

⑨ Charging Indicator

WiTalk HUB: Mini Base Station

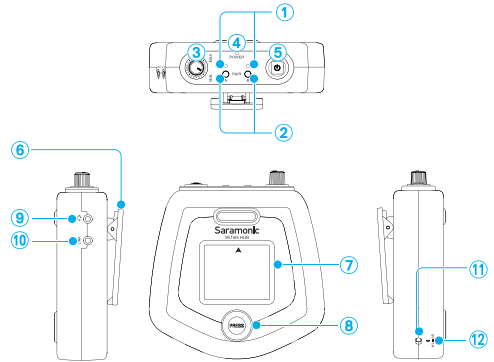

① Pairing Indicator

② Pair Buttons of Channel A and Channel B

③ Volume Control Knob

④ Power Indicator

⑤ Power Button

Press and hold to power on or off.

⑥ Belt Clip

⑦ Battery Compartment

⑧ Release Button

⑨ 3.5mm Headphone & Microphone Combo Jack

⑩ Link Jack

⑪ USB-C Charging Port

⑫ Charging Indicator

WiTalk SRH: Single-Ear Remote Headset

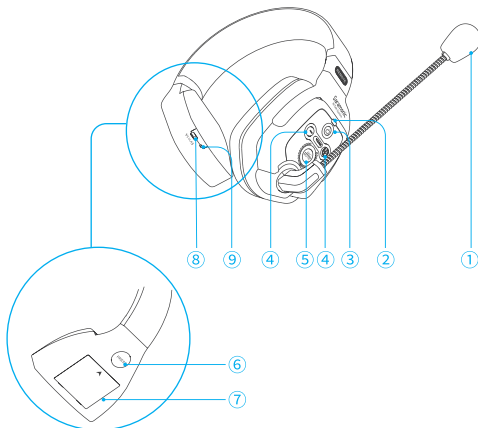

WiTalk LBH: Monaural Intercom Headset

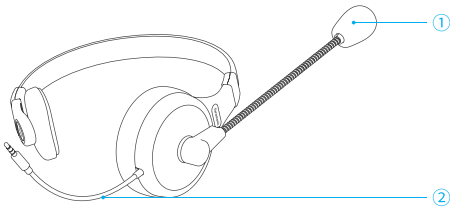

- ① Microphone
- ② Audio Connector
3.5mm TRRS cable

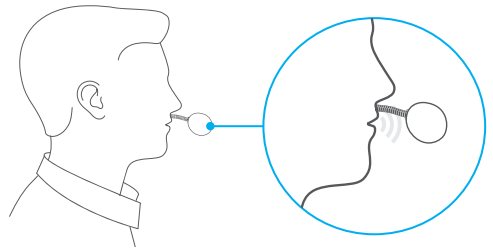

2. Adjust the boom and position the microphone capsule at about 2cm in front of your mouth for optimum audio.

WiTalk CB: 10-Bay Battery Charger

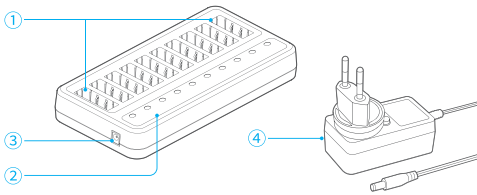

- ① Battery Slots
- ② Charging Indicators
- ③ DC Jack
- ④ 12V/2.5A DC Adapter

(Including four types of detachable plug adapters: Europlug, American Standard, British Standard, Chinese Standard)

How to Use WiTalk LBH

Connect the headset to the  jack of WiTalk HUB

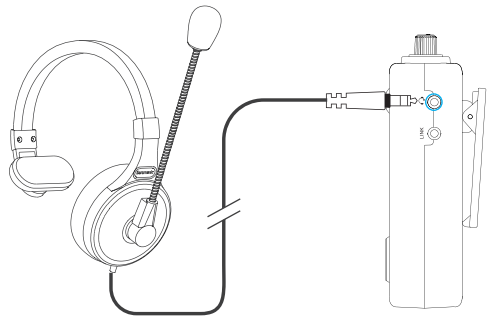

Operation Guide

How to Wear Witalk DMH/DRH/SMH/SRH/LBH

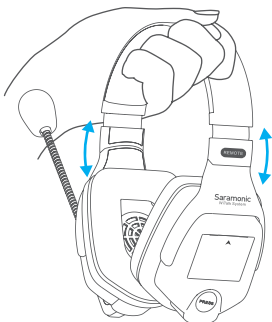

1. Put on the headset and adjust it to a comfortable size and position.

Headsets Pairing

Before leaving the factory, the WiTalk system is pre-paired. Therefore, the connection will be established once they are powered on. If they are disconnected, please follow the below steps:

- Step 1: Make sure that the Master headset and Remote headset(s) are powered off.
- Step 2: When the Master headset is in shutdown mode, press and hold its "+" button and power button simultaneously for about 3 seconds to enter pairing mode. The indicator will blink blue rapidly.
- Step 3: When the Remote headset is in shutdown mode, press and hold its "+" button and power button simultaneously for about 3 seconds to enter pairing mode. The indicator will blink blue rapidly. Do it for all Remote headsets in turn.
- Step 4: When the Master headset and the Remote headset(s) have entered the pairing mode, and the indicator of the Remote headset(s) turns to slowly blink blue, press the power button of the Master headset. They will be successfully paired within 10 seconds, and the indicators of both will turn to static blue.

Note:

1. Each Master headset can have a maximum of four Remote headsets paired.
2. When the number of the Remote headset is up to 4, the Master headset has reached the maximum pairing number by default. The pairing will be successful without the fourth step.
3. If the Master headset couldn't enter the pairing mode, it will automatically turn on after its indicator blinks red rapidly for 5 seconds. This means that the Master headset has reached the maximum pairing number. If you want to re-enable the pairing mode, please clear the Master headset first.
4. The Master headset and Remote headset of the single-ear and dual-ear can be used for paired. The pairing method is the same as above.

Mode	Status Indicator
Unpaired	Blinking blue slowly
Pairing	Blinking blue quickly
Paired Successfully	Static blue

Mini Base Station Pairing

- Step 1: Make sure that the WiTalk HUB and the Remote headset are powered off.
- Step 2: When the WiTalk HUB is in shutdown mode, press and hold its pair button (A or B) and power button simultaneously for about 3 seconds. The indicator will blink blue rapidly, and then the corresponding channel (A or B) enters the pairing mode.
- Step 3: When the Remote headset is in shutdown mode, press and hold its "+" button and power button simultaneously for about 3 seconds to enter pairing mode. The indicator will blink blue rapidly. Do it for all Remote headsets in turn.
- Step 4: When the WiTalk HUB and the Remote headset(s) have entered the pairing mode, and the indicator of the Remote headset(s) turns to slowly blink blue, press the power button of the WiTalk HUB. They will be successfully paired within 10 seconds, and the indicators of both will turn to static blue.

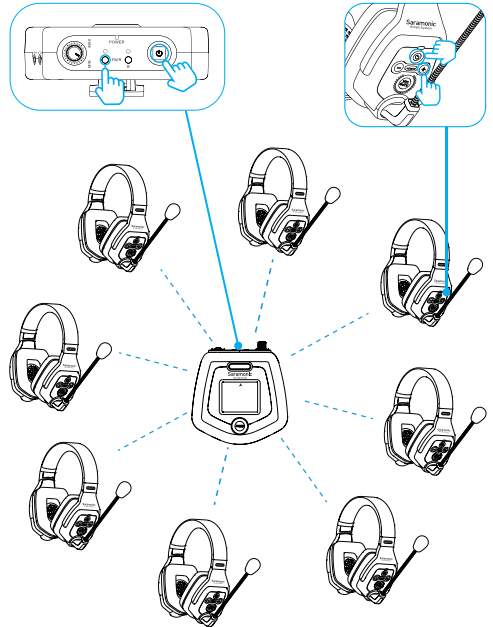
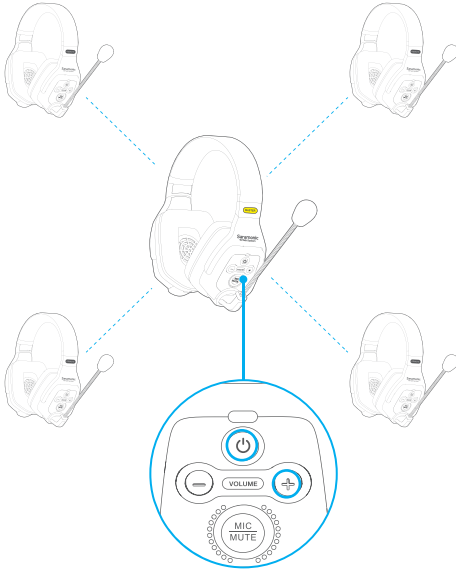

Note: Each channel can have a maximum of 4 Remote headsets paired. Thus, the WiTalk HUB can work with up to 8 Remote headsets simultaneously. After channel A is paired, if necessary, repeat the above steps to pair channel B.

Mode	Status Indicator
Unpaired	Blinking blue slowly
Pairing	Blinking blue quickly
Paired Successfully	Static blue

Clearing the Master Headset

When pairing with a repaired or replaced unit, the Master headset needs to be cleared before a Remote headset can be paired. Follow the steps below to clear the Master headset:

Step 1: Make sure the Master headset is powered off.

Step 2: Press and hold the Master headset's power button and "-" button simultaneously for 10 seconds until its indicator blinks red and blue alternately. When the indicator turns off, the Master headset is cleared.

Clearing the WiTalk HUB

When pairing with a repaired or replaced unit, the WiTalk HUB needs to be cleared before a Remote headset can be paired. Follow the steps below to clear the WiTalk HUB:

Step 1: Make sure the WiTalk HUB is powered off.

Step 2: Press and hold the WiTalk HUB's pair button A and power button simultaneously for 10 seconds. After channel A's indicator blinks blue rapidly for 3 seconds, channel A is cleared and channel B still works normally.

Step 3: Press and hold the WiTalk HUB's pair button B and power button simultaneously for 10 seconds. After channel B's indicator blinks blue rapidly for 3 seconds, channel B is cleared and then the WiTalk HUB will automatically shut down.

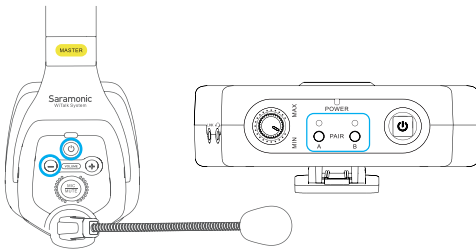

Battery Charging

Please recharge the device when battery is low.

1. Charge the battery via the charger.

① Press the release button to remove the battery.

Mode	Status Indicator
Low Battery	Static red

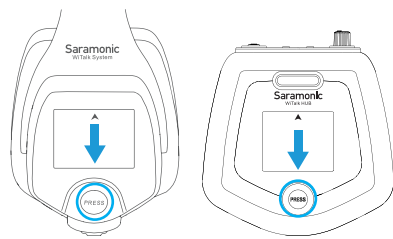

② Insert the battery and make sure the contacts are properly aligned.

Mode	Charging Indicator (Charger)
Charging	Static red
Fully Charged	Static blue

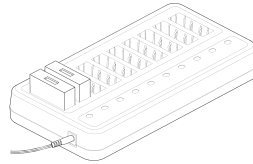

2. Charge the battery via a USB-C charging cable:

Mode	Charging Indicator (Headset)
Charging	Static red
Fully Charged	Static blue

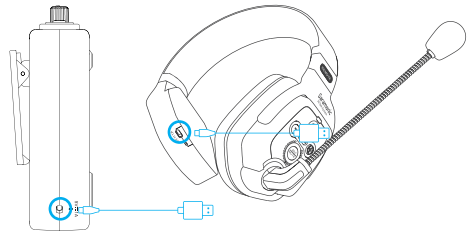

How to Mute Witalk DMH/DRH/SMH/SRH/LBH

Boom can swivel over the top 270 degrees. Thus, headset can be worn on both sides.

You can mute/ unmute the microphone in the following two ways:

①

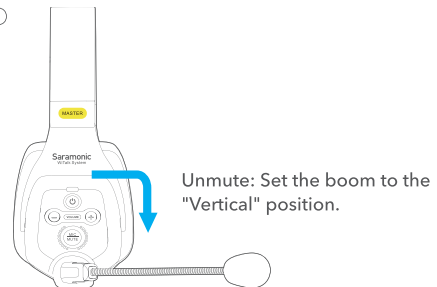

Specifications

Dual-Ear Master Headset (WiTalk DMH)

Duplex mode	Full-Duplex (FDX)
Modulation	GFSK
Carrier frequencies	1787MHz-1928MHz
Microphone type	Condenser microphone
Operating range	Up to 1312ft (400m) without obstacles
Frequency response	300Hz-5KHz
RF output power	<24dBm
Power consumption	<0.5W
SNR	65dB and more
Distortion	<1%
Power requirements	Li-ion Battery 3.7V/1200mAh or USB-C DC 5V
Battery life	Approx. 10 hours (with 2 Remotes), 5 hours (with 4 Remotes)
Weight	Approx. 360g (12.7oz)
Dimensions	175.1x203.1x85.8mm
Operating temperature	-10°C to 50°C
Storage temperature	-20°C to +55°C

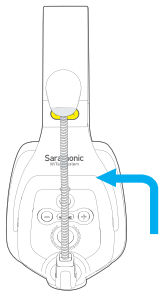

Mute: Set the boom to the "UP" position.

- ② Press the MIC/MUTE button to mute or unmute the microphone.

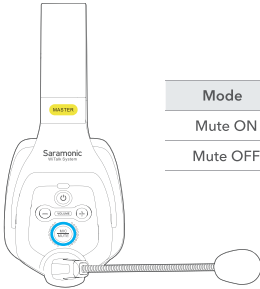

Mode	Status Indicator
Mute ON	Blinking red
Mute OFF	Static blue

Expanding the System

The system is expandable by adding more WiTalk HUB: Use a 3.5mm TRRS to TRRS adapter cable (sold separately) to connect one WiTalk HUB's link jack to another WiTalk HUB's headphone & microphone combo jack, doubling capacity to 16 full-duplex headsets.

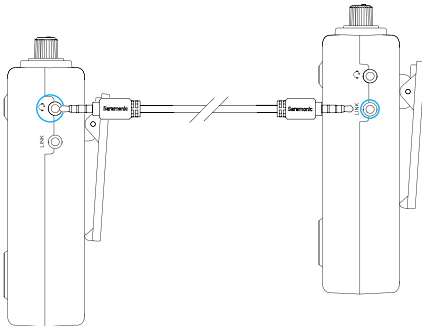

Dual-Ear Remote Headset (WiTalk DRH)

Duplex mode	Full-Duplex (FDX)
Modulation	GFSK
Carrier frequencies	1787MHz-1928MHz
Microphone type	Condenser microphone
Operating range	Up to 1312ft (400m) without obstacles
Frequency response	300Hz-5KHz
RF output power	<24dBm
Power consumption	<0.5W
SNR	65dB and more
Distortion	<1%
Power requirements	Li-ion Battery 3.7V/1200mAh or USB-C DC 5V
Battery life	Approx. 18 hours
Weight	Approx. 360g (12.7oz)
Dimensions	175.1x203.1x85.8mm
Operating temperature	-10°C to 50°C
Storage temperature	-20°C to +55°C

Single-Ear Master Headset (WiTalk SMH)

Duplex mode	Full-Duplex (FDX)
Modulation	GFSK
Carrier frequencies	1787MHz-1928MHz
Microphone type	Condenser microphone
Operating range	Up to 1312ft (400m) without obstacles
Frequency response	300Hz-5kHz
RF output power	<24dBm
Power consumption	<0.5W
SNR	65dB and more
Distortion	<1%
Power requirements	Li-ion Battery 3.7V/1200mAh or USB-C DC 5V
Battery life	Approx. 10 hours (with 2 Remotes), 5 hours (with 4 Remotes)
Weight	Approx. 360g (12.7oz)
Dimensions	175.1x203.1x85.8mm
Operating temperature	-10°C to 50°C
Storage temperature	-20°C to +55°C

Single-Ear Remote Headset (WiTalk SRH)

Duplex mode	Full-Duplex (FDX)
Modulation	GFSK
Carrier frequencies	1787MHz-1928MHz
Microphone type	Condenser microphone
Operating range	Up to 1312ft (400m) without obstacles
Frequency response	300Hz-5kHz
RF output power	<24dBm
Power consumption	<0.5W
SNR	65dB and more
Distortion	<1%
Power requirements	Li-ion Battery 3.7V/1200mAh or USB-C DC 5V
Battery life	Approx. 18 hours
Weight	Approx. 360g (12.7oz)
Dimensions	175.1x203.1x85.8mm
Operating temperature	-10°C to 50°C
Storage temperature	-20°C to +55°C

Mini Base Station (WiTalk HUB)

Duplex mode	Full-Duplex (FDX)
Modulation	GFSK
Carrier frequencies	1787MHz-1928MHz
Operating range	Up to 1312ft (400m) without obstacles
Frequency response	300Hz-5kHz
RF output power	<24dBm
Power consumption	<0.5W
SNR	≥65dB
Distortion	<1%
Power requirements	3.7V/1200mAh Li-ion Battery or USB-C DC 5V
Battery life	Approx. 2.5 hours (with 8 Remotes), Approx. 5 hours (with 4 Remotes)
Weight	Approx. 180g (6.35oz)
Dimensions	127.6x119.4x46.5mm
Operating temperature	-10°C to 50°C
Storage temperature	-20°C to 55°C

Standards for Radio Frequency Band

Product Versions	Frequency Range	Regions Available
Standard Version	1880-1900MHz	Europe: The United Kingdom; Hong Kong; South Africa; Malaysia; Australia; New Zealand;
American Version	1920-1930MHz	United States; Canada; Mexico
Japanese Version	1893-1906MHz	Japan
Taiwanese Version	1880-1895MHz	Taiwan
Brazilian Version	1910-1920MHz	Brazil

For the latest frequency band and the more countries, please refer to our official website: www.saramonic.com

Packing List

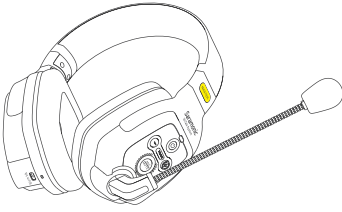

WiTalk DMH Dual-Ear Master Headset

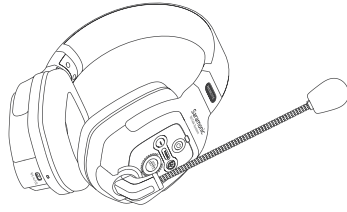

WiTalk DRH Dual-Ear Remote Headset

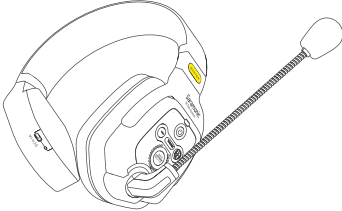

WiTalk SMH Single-Ear Master Headset

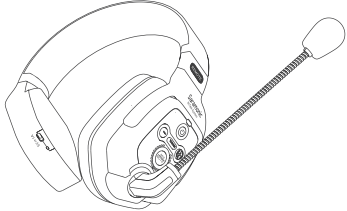

WiTalk SRH Single-Ear Remote Headset

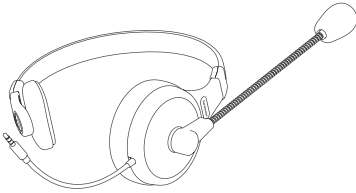

WiTalk LBH Monaural Intercom Headset

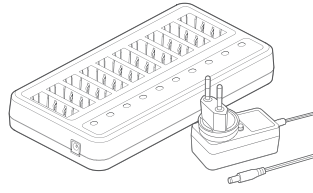

WiTalk CB Battery Charger



WiTalk HUB Mini Base Station



WiTalk BP Rechargeable Battery

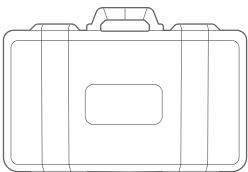

WiTalk Carrying Case (S/M/L)



WiTalk Link Cable-30M (sold separately)

WiTalk WT2D

1* WiTalk DMH Headset
1* WiTalk DRH Headset
2* WiTalk BP Battery
2* USB-C Charging Cable
1* WiTalk Carrying Case (S)

WiTalk WT2S

1* WiTalk SMH Headset
1* WiTalk SRH Headset
2* WiTalk BP Battery
2* USB-C Charging Cable
1* WiTalk Carrying Case (S)

WiTalk WT3D

1* WiTalk DMH Headset
2* WiTalk DRH Headset
3* WiTalk BP Battery
3* USB-C Charging Cable
1* WiTalk Carrying Case (S)

WiTalk WT3S

1* WiTalk SMH Headset
2* WiTalk SRH Headset
3* WiTalk BP Battery
3* USB-C Charging Cable
1* WiTalk Carrying Case (S)

WiTalk WT4D

1* WiTalk DMH Headset
3* WiTalk DRH Headset
4* WiTalk BP Battery
4* USB-C Charging Cable
1* WiTalk Carrying Case (S)

WiTalk WT4S

1* WiTalk SMH Headset
3* WiTalk SRH Headset
4* WiTalk BP Battery
4* USB-C Charging Cable
1* WiTalk Carrying Case (S)

WiTalk WT5D

1* WiTalk DMH Headset
4* WiTalk DRH Headset
5* WiTalk BP Battery
1* WiTalk CB Battery Charger
1* WiTalk Carrying Case (M)

WiTalk WT5S

1* WiTalk SMH Headset
4* WiTalk SRH Headset
5* WiTalk BP Battery
1* WiTalk CB Battery Charger
1* WiTalk Carrying Case (M)

WiTalk WT6D

1* WiTalk HUB Base Station
5* WiTalk DRH Headset
6* WiTalk BP Battery
1* WiTalk CB Battery Charger
1* WiTalk LBH Headset
1* WiTalk Carrying Case (M)

WiTalk WT6S

1* WiTalk HUB Base Station
5* WiTalk SRH Headset
6* WiTalk BP Battery
1* WiTalk CB Battery Charger
1* WiTalk LBH Headset
1* WiTalk Carrying Case (M)

WiTalk WT7D

1* WiTalk HUB Base Station
6* WiTalk DRH Headset
7* WiTalk BP Battery
1* WiTalk CB Battery Charger
1* WiTalk LBH Headset
1* WiTalk Carrying Case (L)

WiTalk WT7S

1* WiTalk HUB Base Station
6* WiTalk SRH Headset
7* WiTalk BP Battery
1* WiTalk CB Battery Charger
1* WiTalk LBH Headset
1* WiTalk Carrying Case (L)

WiTalk WT8D

1* WiTalk HUB Base Station
7* WiTalk DRH Headset
8* WiTalk BP Battery
1* WiTalk CB Battery Charger
1* WiTalk LBH Headset
1* WiTalk Carrying Case (L)

WiTalk WT8S

1* WiTalk HUB Base Station
7* WiTalk SRH Headset
8* WiTalk BP Battery
1* WiTalk CB Battery Charger
1* WiTalk LBH Headset
1* WiTalk Carrying Case (L)

WiTalk WT9D

1* WiTalk HUB Base Station
8* WiTalk DRH Headset
9* WiTalk BP Battery
1* WiTalk CB Battery Charger
1* WiTalk LBH Headset
1* WiTalk Carrying Case (L)

WiTalk WT9S

1* WiTalk HUB Base Station
8* WiTalk SRH Headset
9* WiTalk BP Battery
1* WiTalk CB Battery Charger
1* WiTalk LBH Headset
1* WiTalk Carrying Case (L)



For better recording experience, the application **SmartRecorder** is recommended.

为获得更好的录制体验，推荐使用枫笛 Saramonic 自主研发应用软件 **SmartRecorder**。



Scan the QR code and follow us!
扫描微信关注枫笛公众号!

Shenzhen Jiayz Photo Industrial., Ltd
深圳市长丰影像器材有限公司

A16 Building, Intelligent Terminal Industrial Park of Silicon Valley
Power, Guanlan, Longhua District, Shenzhen, China
深圳市龙华区观澜街道大富工业区硅谷动力智能终端产业园A16栋